

SAE Technical Standards Board Rules provide that: "This report is published by SAE to advance the state of technical and engineering sciences. The use of this report is entirely voluntary, and its applicability and suitability for any particular use, including any patent infringement arising therefrom, is the sole responsibility of the user." SAE reviews each technical report at least every five years at which time it may be revised, reaffirmed, stabilized, or cancelled. SAE invites your written comments and suggestions.

**REV. B**

**AS9596**

FEDERAL SUPPLY CLASS  
5340

**RATIONALE**

THIS DOCUMENT HAS BEEN DETERMINED TO CONTAIN BASIC AND STABLE TECHNOLOGY WHICH IS NOT DYNAMIC IN NATURE. THIS STANDARD HAS BEEN STABILIZED.

**STABILIZED NOTICE**

THIS DOCUMENT HAS BEEN DECLARED "STABILIZED" BY THE SAE E-25 GENERAL STANDARDS FOR AEROSPACE AND PROPULSION SYSTEMS COMMITTEE AND WILL NO LONGER BE SUBJECTED TO PERIODIC REVIEWS FOR CURRENCY. USERS ARE RESPONSIBLE FOR VERIFYING REFERENCES AND CONTINUED SUITABILITY OF TECHNICAL REQUIREMENTS. NEWER TECHNOLOGY MAY EXIST.

**SAE values your input. To provide feedback on this Technical Report, please visit <http://www.sae.org/technical/standards/AS9596B>**

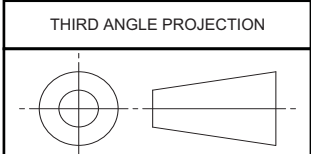

ISSUED 1998-02 REVISED 2005-12 STABILIZED 2014-03

CUSTODIAN: E-25		PROCUREMENT SPECIFICATION: NONE	
	<b>AEROSPACE STANDARD</b>		<b>AS9596</b>
	BRACKET, ANGLE, 90°, CADMIUM PLATED, STEEL UNS G41300, .190 BOLT		

WARNING

THIS DOCUMENT INCLUDES CADMIUM AS A PLATING MATERIAL. THE USE OF CADMIUM HAS BEEN RESTRICTED AND/OR BANNED FOR USE IN MANY COUNTRIES DUE TO ENVIRONMENTAL AND HEALTH CONCERNS. THE USER SHOULD CONSULT WITH LOCAL OFFICIALS ON THE ENVIRONMENTAL AND HEALTH REGULATIONS REGARDING ITS USE.

THE INITIAL SAE PUBLICATION OF THIS DOCUMENT WAS TAKEN DIRECTLY FROM U.S. MILITARY STANDARD MS9596B. THIS SAE STANDARD RETAINS THE SAME PART NUMBERS ESTABLISHED BY THE ORIGINAL MILITARY DOCUMENT.

ANY REQUIREMENTS ASSOCIATED WITH QUALIFIED PRODUCT LISTS (QPL) MAY CONTINUE TO BE MANDATORY FOR DOD CONTRACTS. REQUIREMENTS RELATING TO QPL'S HAVE NOT BEEN ADOPTED BY THE SAE FOR THIS STANDARD AND ARE NOT PART OF THIS SAE DOCUMENT.

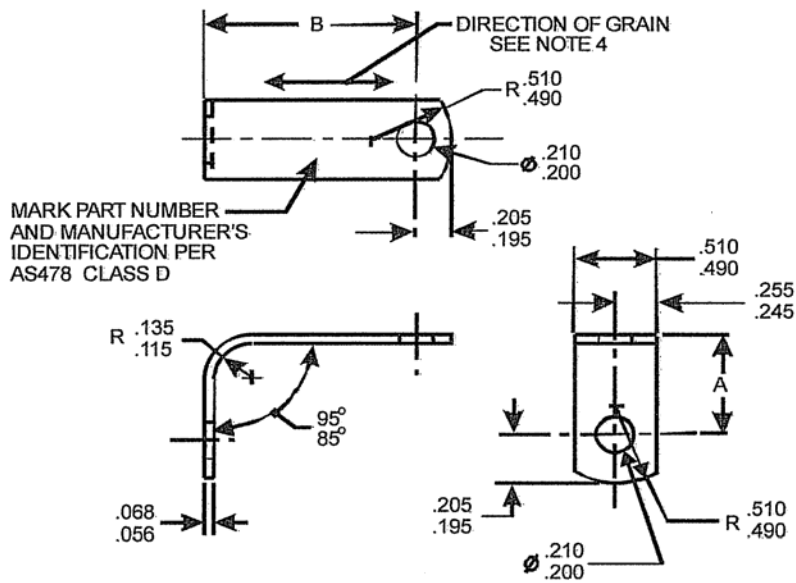

FIGURE 1 - ANGLE BRACKET



AEROSPACE STANDARD

BRACKET, ANGLE, 90°,  
CADMIUM PLATED, STEEL  
UNS G41300, .190 BOLT

AS9596  
SHEET 1 OF 4

REV.  
B